

FAST LINE

FORNI ELETTRONICI ED ANALOGICI PER GASTRONOMIA E PASTICCERIA

ELECTRONIC AND ANALOGIC OVENS FOR GASTRONOMY AND PASTRY

ELEKTRONISCHEN UND ANALOGEN ÖFEN FÜR GASTRONOMIE UND KONDITOREI

FOURS ÉLECTRONIQUES ET ANALOGIQUES POUR GASTRONOMIE ET PÂTISSERIE

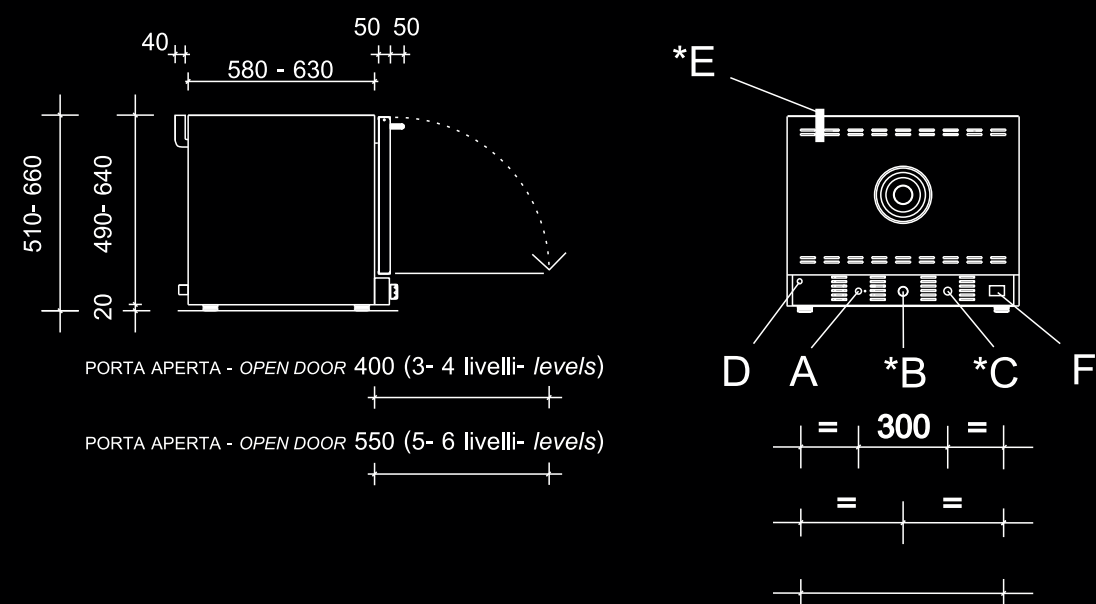

LEGENDA

- A Connessioni elettriche (230V~1 50Hz; 400V~3N 50Hz)
- * B Scarico acqua Ø 32 mm (si raccomanda l'installazione di un sifone)
- * C Ingresso acqua (per vapore) 3/4"
- D Pulsante ripristino termostato di sicurezza
- * E Tubo di sfiato vapore della cella
- F Morsetto equipotenziale

LEGEND

- A Electrical connections (230V~1 50Hz; 400V~3N 50Hz)
- * B Water drain Ø 32 mm (it is recommend to install a siphon)
- * C Water inlet (for steam) 3/4"
- D Button reset of the safety thermostat
- * E Steam waste pipe
- F Equipotential terminal

LEGEND

- A Elektro-Anschluss (230V~1 50Hz; 400V~3N 50Hz)
- * B Wasserablauf Ø 32 mm (zwischen dem Ofen und dem Umgebungsauslassrohr muss ein Siphon vorgenommen werden)
- * C Wassereinlauf (für Dampf) 3/4"
- D Manuelle Instandsetzung des Sicherheitsthermostats
- * E Dampfablüftung
- F Potentialausgleichsklemme

LÉGENDE

- A Connexions électriques (230V~1 50Hz; 400V~3N 50Hz)
- * B Degivrage eau Ø 32 mm (on recommande l'installation de un siphon)
- * C Arrivée eau (pour vapeur)
- D Reset manuel du thermostat de sûreté
- * E Tuyau décharge vapeur
- F Plaque à bornes équipotentielles

- * = presente solo nel modello convezione vapore
- * = only in combined convection-steam ovens
- * = für heissluftdampföfen
- * = seulement dans les fours mixtes à convection et vapeur direct

La ditta declina ogni responsabilità per eventuali errori di stampa, riservandosi di apportare senza preavviso le modifiche che riterrà più opportune. - The manufacturer reserves the right to modify any product without prior notice. Änderungen im Interesse des Lesers behalten wir uns vor. - Le fabricant se réserve le droit d'apporter des modifications aux caractéristiques techniques et fonctionnelles dans cette publication sans aucun préavis.

ELETTRONICI- ELECTRONICS							
MODELLO MODEL	DIMENSIONI ESTERNE EXTERNAL DIMENSIONS (*)LxPxH (mm) (*)WxDxH (mm)	DIMENSIONI INTERNE UTILI INT. WORKING DIMENSIONS LxPxH (mm) WxDxH (mm)	GRIGLIE TEGLIE GRIDS TRAY (N°)	 (kW)	POTENZA TOTALE TOTAL POWER (kW)	VOLUME IMBALLO PACKED VOLUME (m³)	PESO LORDO GROSS WEIGHT (Kg)
CONVEZIONE CONVECTION	FCE-803-HR	620x670x510	500x370x300 3 GN 2/3 440x350	3	3,2 230V~1N 50Hz	0,34	42
	FCE-805-HR	620x670x660	500x370x450 5 GN 2/3 440x350	3,35	3,55 230V~1N 50Hz	0,41	50
	FCE-903-HR	780x720x510	660x420x300 3 GN1/1 400X600	3,35	3,55 230V~1N 50Hz	0,45	52
	FCE-905-HR	780x720x660	660x420x450 5 GN1/1 400X600	5,5	5,7 400V~3N 50Hz	0,55	65
CONVEZIONE- VAPORE CONVECTION- STEAM	FDE-803-HR	620x670x510	500x370x300 3 GN1/1 400X600	3	3,2 230V~1N 50Hz	0,34	42
	FDE-805-HR	620x670x660	500x370x450 5 GN1/1 400X600	3,35	3,55 230V~1N 50Hz	0,41	50
	FDE-903-HR	780x720x510	660x420x300 3 GN1/1 400X600	3,35	3,55 230V~1N 50Hz	0,45	52
	FDE-905-HR	780x720x660	660x420x450 5 GN1/1 400X600	5,5	5,7 400V~3N 50Hz	0,55	65

ANALOGICI- ANALOGICS							
MODELLO MODEL	DIMENSIONI ESTERNE EXTERNAL DIMENSIONS (*)LxPxH (mm) (*)WxDxH (mm)	DIMENSIONI INTERNE UTILI INT. WORKING DIMENSIONS LxPxH (mm) WxDxH (mm)	GRIGLIE TEGLIE GRIDS TRAY (N°)	 (kW)	POTENZA TOTALE TOTAL POWER (kW)	VOLUME IMBALLO PACKED VOLUME (m³)	PESO LORDO GROSS WEIGHT (Kg)
UMIDIFICAZIONE HUMIDIFICATION	FUE-904-HR	780x720x510	660x420x300 4 GN1/1 400X600	3,35	3,55 230V~1N 50Hz	0,45	52
	FUE-906-HR	780x720x660	660x420x450 6 GN1/1 400X600	5,5	5,7 400V~3N 50Hz	0,55	65

(*) L= LARGHEZZA TOTALE CORPO - (*) W= TOTAL BODY WIDTH

P= PROFONDITA': CORPO + PORTA + SCARICHI (tubi, cavi, camini...) - D= DEPTH: BODY + DOOR+ VENTS (cables, pipes, tubes...)

H= ALTEZZA: CORPO + PIEDINI + SCARICHI (tubi, cavi, camini...) - H= HEIGHT: BODY + FEET + VENTS (cables, pipes, tubes...)

LE MISURE LxPxH SONO L'INGOMBRO MASSIMO DEL FORNO ESCLUSA LA MANIGLIA
MEASURES WxDxH ARE THE MAXIMUM DIMENSIONS OF THE OVEN EXCLUDING THE HANDLE
MISST BxTxH SIND DIE MAXIMALEN ABMESSUNGEN DES OFENS OHNE DEN GRIFF
MESURE LxPxH SONT LES DIMENSIONS MAXIMALES DU FOUR EXCLUSION DE LA POIGNÉE

FORNI ELETTRICI, ELETTRONICI - ELECTRICAL, ELECTRONIC OVENS

5 2/3 GN1/1, 440x350 mm; 3- 5 GN1/1, 400x600 mm



Convezione- Convection



Convezione e Vapore - Convection and Steam

FORNI ELETTRICI, ANALOGICI - ELECTRICAL ANALOGIC OVENS

4- 6 GN1/1, 400x600 mm



Convezione e Umidificazione - Convection and Humidification

LA SOLUZIONE IDEALE PER LA RISTORAZIONE VELOCE

THE IDEAL SOLUTION FOR FAST COOKING

DIE OPTIMALE LÖSUNG FÜR FASTGAREN

LA SOLUTION IDÉALE POUR LA RESTAURATION RAPIDE

Costruiti in acciaio inox- Camera interna con angoli arrotondati per facilitare la pulizia- Controllo digitale, intuitivo, semplice da usare- Possibilità di memorizzare fino a 20 programmi di cottura- 3 fasi di cottura- Pre-riscaldamento- Fondo stampato in tutti i modelli; piletta di scarico nei modelli a convezione-vapore - Inversione automatica del senso di rotazione delle ventole- Controllo dell'umidità (solo nella versione a convezione-vapore)- Illuminazione interna- Guarnizione ad incastro sulla camera di cottura- Porta a ribalta con doppio vetro- Struttura porta teglie-griglie con passo 75 mm (nei modelli FUE, 65 mm), facilmente smontabile per una migliore pulizia.

Made in inox- Cooking chamber with rounded edges for easy cleaning- Digital, intuitive control panel- Possibility to memorize 20 cooking programs- 3 phases of cooking- Pre-heating- Moulded bottom in all the models; drainage pipe in combined convection and direct steam injection models- Automatic fan rotation reverse- Manual control of humidity (only for combined convection and direct steam injection ovens)- Internal lighting- Snap-on seals on cooking chamber- Double glazed tilting up door- Wire rack to hold grid and trays 75 mm steps (65mm steps FUE models) easily removable for a better cleaning.

Komplett aus inox- Intern mit kugelecken welche fuer ein einfaches putzen geeignet sind- Digital kontrolle- Moeglichkeit 20 programme zu speichern- 3 Koch phasen- Vorheizung- Tiefgezogen Boden- Tauwasserablauf (für Heissluftdamföfen)- Automatische Umkehrung der Drehrichtung des Heissluftgebläses- Luftfeuchtigkeitskontrolle (für Heissluftdamföfen)- Interne Beleuchtung- Inklemdichtung an der garkammer- Kipptüre mit Doppelglas- Struktur, Blech und Rost-Halterun mit 75 mm-Raster (65 mm für FUE modelle) , leicht herausnehmbar, um die Reinigung zu erleichtern.

Construit en acier inox- Chambre de cuisson avec des angles arrondis pour faciliter le nettoyage- Panneau de contrôle digital et intuitif- Possibilité de mémoriser 20 programmes de cuisson- 3 Phases de cuisson- Pre-Chauffage- Fond embouti- Conduit de décharge (pour les fours convection et vapeur)- Inverseur automatique du sens de rotation du ventilateur- Contrôle de l'humidité (pour les fours convection et vapeur)- Eclairage en chambre de cuisson- Joint encastrable sur la chambre de cuisson- Porte basculante double vitre- Structure porte-bacs et grilles en fil inox avec un inter axe de 75 mm (65 mm pour FUE modeles), amovible, pour le nettoyage

FORNI ELETTRONICI A CONVEZIONE - CONVECTION ELECTRONIC OVENS



FORNI ELETTRONICI A CONVEZIONE-VAPORE - CONVECTION-STEAM ELECTRONIC OVENS



- UMIDITÀ / HUMIDITY
LUFTFEUCHTIGKEIT / HUMIDITÉ
- TEMPO DI COTTURA / COOKING TIME
KOCHEIT / TEMPS DE CUISSON
- TEMPERATURA DI COTTURA
COOKING TEMPERATURE
KOCHETEMPERATUR
TEMPÉRATURE DE CUISSON
- MENÙ-SALVA / MENU-SAVE
MENÜ-SPEICHERN / MENU-ENREGISTER
- AUMENTO DELL'UMIDITÀ
MANUAL INCREASE OF HUMIDITY
MANUELLE LUFTFEUCHTIGKEITSTEIGERUNG
AUGMENTATION MANUEL DE L'HUMIDITÉ
- START- STOP- PAUSA / START- STOP- PAUSE
START- STOP- PAUSE / START- STOP- PAUSE
- FASE DI COTTURA / COOKING PHASES
KOCHEPHASEN / PHASES DE CUISSON
- SELEZIONE-CONFERMA / SELECTION-CONFIRM
AUSWAHL-BESTÄTIGUNG / SELECTION-CONFIRMIR

FORNI ANALOGICI CON UMIDIFICAZIONE - ANALOGIC OVENS WITH HUMIDIFICATION

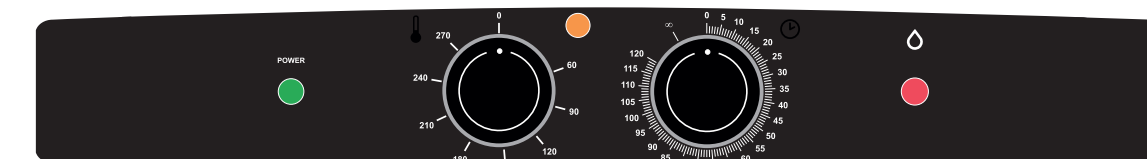

- ACCENSIONE
POWER
EINSCHALTEN
MISE EN MARCHÉ
- RISCALDAMENTO
HEATING
ERWÄRMEN
RÉCHAUFFEMENT
- TEMPO DI COTTURA
COOKING TIME
KOCHEIT
TEMPS DE CUISSON
- TEMPERATURA DI COTTURA
COOKING TEMPERATURE
KOCHETEMPERATUR
TEMPÉRATURE DE CUISSON
- UMIDITÀ FORNO
OVEN HUMIDITY
BACKOFEN LUFTFEUCHTIGKEIT
HUMIDITÉ FOUR



Guarnizione ad incastro
Snap-on seals
Inklemdichtung
Joint encastrable



Struttura porta griglie e teglie
Wire rack to hold grid and trays
Struktur, Blech -und Rost-Halterun
Structure porte-bacs et grilles



Illuminazione interna
Chamber light
Innere Beleuchtung
Éclairage en chambre de cuissons



Scarico
Drainage
Wassereablauf
Degivrage de l'eau

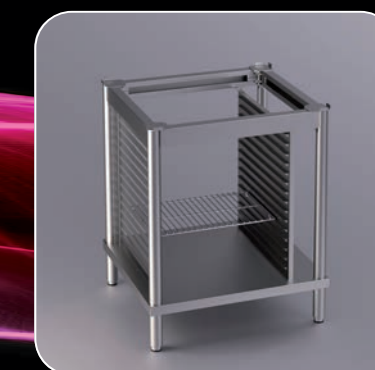

Supporti aperti (2/3GN, 440x350, GN1/1, 400x600)
Open stands (2/3GN, 440x350, GN1/1, 400x600)
Unterbau (2/3GN, 440x350, GN1/1, 400x600)
Support ouvert (2/3GN, 440x350, GN1/1, 400x600)

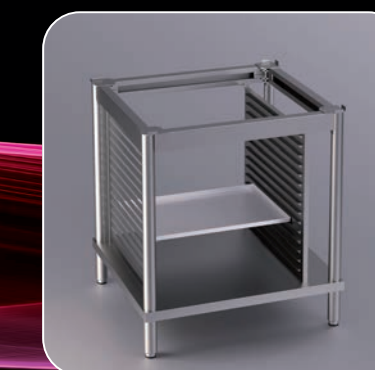

Cella di lievitazione (400x600)
Proofer (400x600)
Befeuchtet Wärmeschranke (400x600)
Armoire à fermentation (400x600)