

ABX 530
ABX 610
ABX 710



ABX Porta in acciaio inox
Stainless steel door
Porte en inox
Tür aus Inox
Puerta en acero inox

Congelatori industriali
Freezers for the industry
Congélateurs industriels
Gewerbliche-Tiefkühlgeräte
Congeladores industriales

Esterno in acciaio verniciato bianco.
Interno in alluminio
Outside made of white painted steel.
Inside aluminium / Extérieur en acier
peint en blanc. Intérieur en aluminium
/ Außenfläche aus weißlackie- rtem
Stahl. Innenfläche aus Aluminium /
Externo de acero pintado blanco.
Interno de aluminio

PORTA ACCIAIO INOX
IDEALE PER PICCOLE
PREPARAZIONI DI PIATTI

STAINLESS STEEL LID
FOR PREPARING FOOD

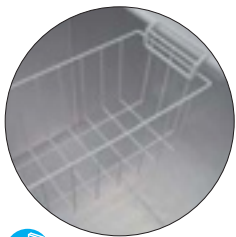

Cesti di serie
Serial baskets
Paniers de serie
Serien Koerbe
Canastos de serie

ABX

Porta in acciaio inox
Stainless steel door
Porte en inox
Tür aus Inox
Puerta en acero inox

Acciaio verniciato grigio
Grey painted stainless steel
Acier verni en gris
Stahl grau lackiert
Acero pintado de color gris



ABX 396
ABX 506

Esterno in acciaio verniciato grigio.
Interno in alluminio
Outside made of grey painted steel.
Inside aluminium / Extérieur en acier
peint en gris. Intérieur en aluminium /
Außenfläche aus graulackier tem Stahl.
Innenfläche aus Aluminium / Exte- rno
de acero pintado gris. Interno de aluminio



	Watt		°C			H ₂ O		Lt.	Serie	Max	mm. (LxPxH)				Kg.
ABX 396	145	230v/1/50Hz	-17/-24			MAN	R 600	362	n° 2	n° 4	1260x695x850	Di serie	Di serie	1	55
ABX 506	190	230v/1/50Hz	-17/-24			MAN	R 600	463	n° 2	n° 5	1560x695x850	Di serie	Di serie	1	60
ABX 530	173	230v/1/50Hz	-12/-25			MAN	R 134a	504	n° 3	n° 4	1500x730x860	Di serie	Di serie	1	67
ABX 610	226	230v/1/50Hz	-12/-25			MAN	R 134a	580	n° 3	n° 5	1700x730x860	Di serie	Di serie	1	77
ABX 710	276	230v/1/50Hz	-12/-25			MAN	R 134a	670	n° 3	n° 6	1800x770x860	Di serie	Di serie	1	85

Prezzi vedi a pagina 43
Prices see page 43

Dati di collaudo - Test details - Détails d'essai - Prüfungsergebnisse - Datos de ensayo - MAX = (30°C - % U.R. 55)

PICCOLA ESPOSIZIONE
SMALL DISPLAYS
REFRIGERATORI & CONGELATORI
REFRIGERATORS & FREEZERS
MINIBAR & FARMACIA
MINIBAR & PHARMACY
ARMADI SPECIALI
SPECIAL CABINETS
PASTICCERIA
PASTRY
RISTORAZIONE
CATERING EQUIPMENT
PIZZERIA
PIZZERIA
SUPERMERCATI
SUPERMARKETS
IPERMERCATI
HYPERMARKETS
ATTREZZATURE COMPLEMENTARI al servizio
ADDITIONAL EQUIPMENT'S SERVICE

VLC

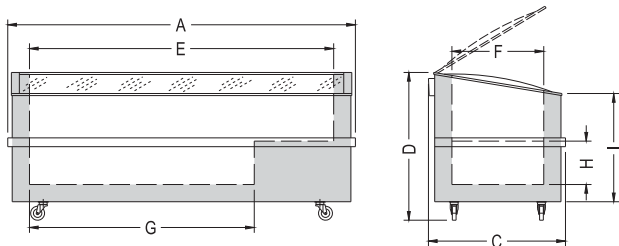

Interno ed esterno in lamiera plastificata bianca
 Inside and outside in white metal plastified sheet.
 Intérieur et extérieur en plaque blanche plastifiée.
 Innenseite und Oberseite aus weisse Kunststoff-platte.
 Interior y exterior en chapa blanca plastificada.

Spie di controllo: corrente, congelazione rapida, allarme
 Control pilot lamps: current, quick-freezing, alarm
 Lampes témoins de contrôle: courant, congélation rapide, alert
 Kontrollampen: Strom, schnelles Gefrieren, Alarm
 Pilotos de control: corriente, congelación rápida, alarma

DIMENSIONI / SIZE / DIMENSIONS / MABE / MEDIDAS

	A (mm)	C (mm)	D (mm)	E (mm)	F (mm)	G (mm)	H (mm)	I (mm)
VLC 320	1100	600	830	980	480	670	280	730
VLC 430	1400	600	830	1280	480	970	280	730
VLC 550	1810	600	830	1690	480	1380	280	730

Termometro interno
 Internal Thermometer
 Thermomètre intérieur
 Innenthermometer
 Termómetro interior

Cerniere con molla
 Hinges with spring
 Charnières avec ressort
 Scharniere mit Feder
 Bisagras con quelle

Coperchio anticondensa
 Anticondence cover
 Couvercle anti-condensation
 Antikondensation Deckel
 Tapa anticondensación

AB / ABX

AB 200 / 240 / 300 / 350 / 396 / 425 / 506:

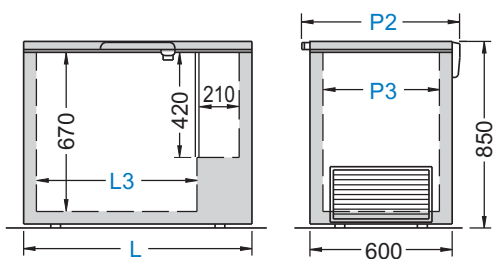

AB 530 / 610 / 710:

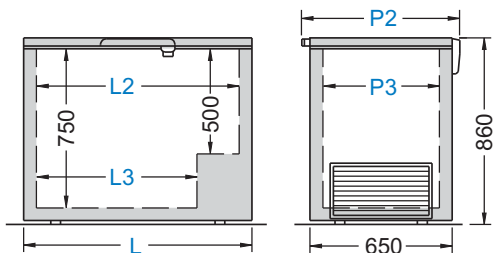

DIMENSIONI

SIZE / DIMENSIONS / MABE / MEDIDAS

	L (mm)	L2 (mm)	L3 (mm)	P2 (mm)	P3 (mm)
AB 200	720	-	410	695	500
AB 240	850	-	540	695	500
AB 300	1020	-	710	695	500
AB 350	1125	-	815	695	500
AB 396	1260	-	950	695	500
AB 425	1370	-	1060	695	500
AB 506	1560	-	1250	695	500
AB 530	1500	1386	1186	730	536
AB 610	1700	1586	1386	730	536
AB 710	1800	1686	1486	770	576

Termometro esterno / External Thermometer
 Thermomètre extérieur / Aussenthermometer / Termómetro exterior

*** AB 108**
 Termometro interno
 Internal Thermometer
 Thermomètre intérieur
 Innenthermometer
 Termómetro interior

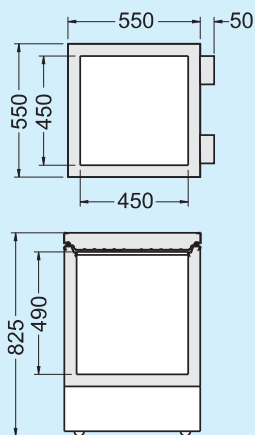

AB 780

NEW

Spessore di isolamento mm. 70
 Insulation thickness 70 mm.
 Epaisseur d'isolation 70 mm.
 Isolierstärke 70 mm.
 Espesor de aislamiento 70 mm.

Termometro esterno
 External Thermometer
 Thermomètre extérieur
 Aussenthermometer
 Termómetro exterior

Esterno in acciaio verniciato bianco. Interno in alluminio
 Outside made of white painted steel. Inside aluminium
 Extérieur en acier peint en blanc. Intérieur en aluminium
 Außenfläche aus weißlackiertem Stahl. Innenfläche aus Aluminium
 Externo de acero pintado blanco. Interno de aluminio

 Nr. cesti di serie No. serial baskets Nr. paniers de serie Nr. serien Korbbe Nr. canastos de serie	 Capacità totale cesti Total capacity of baskets Capacité totale paniers Totale kapazität Korbbe Capacidad total canastos
N° 2 mm. 260x624 h. 260	N° 6 mm. 260x624 h. 260

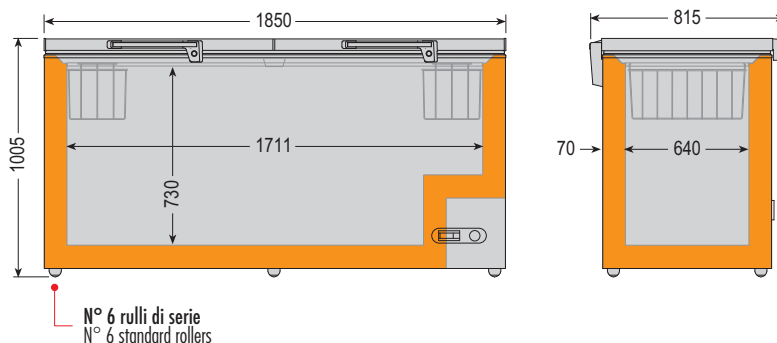

N° 6 rulli di serie
 N° 6 standard rollers

AB 800

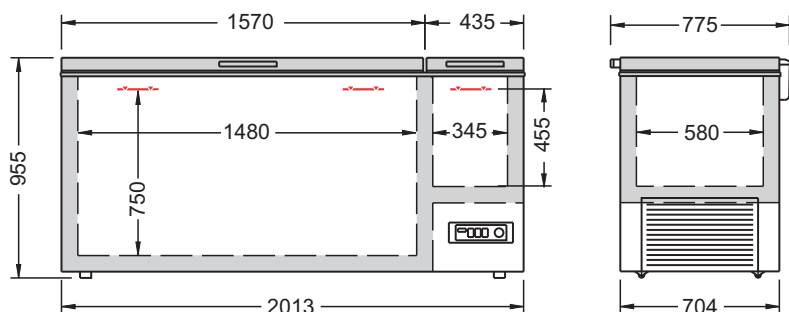

Termometro esterno
 External Thermometer
 Thermomètre extérieur
 Aussenthermometer
 Termómetro exterior

ONE
OMEGA
 professional equipment

http://www.omegaone.gr email: info@omegaone.gr
 Tel: 0030 2103472270 Fax: 0030 2103476037